

Features

- Through holes in body enable simple mounting.
- Body manufactured from high tensile, anodised aluminum giving good resistance to corrosion.
- Available with sensors.
- Magnetic as standard.

Order example

MCHG2 – 16 M – □

MODEL

TUBE I.D.
16, 20, 25, 32, 40,
50, 63, 80, 100, 125

M: Magnet
* Magnetic as standard.

PORT THREAD
Blank: M thread
(only for $\phi 16\sim\phi 63$)
Blank: Rc thread
G: G thread
NPT: NPT thread
(only for $\phi 80\sim\phi 125$)

Specification

Model	MCHG2										
Acting type	Double acting										
Tube I.D. (mm)	16	20	25	32	40	50	63	80	100	125	
Stroke (mm)	4	4	6	8	8	12	16	20	24	32	
Port size	M3×0.5	M5×0.8						Rc1/8	Rc1/4	Rc3/8	
Medium	Air										
Operating pressure (MPa)	0.2~0.6					0.1~0.6					
Ambient temperature	-10~+60°C (No freezing)										
Repeatability	±0.01 mm										
Max. operating frequency (c.p.m)	120				60				30		
Lubrication	Not required										
Effective gripping force N (lbf) at (0.5 MPa) (*)	External	14(3.1)	25(5.6)	42(9.4)	74(16.6)	118(26.5)	187(42)	335(75)	500(112)	750(169)	1270(285)
	Internal	16(3.6)	28(6.3)	47(10.6)	82(18.4)	130(29)	204(46)	359(81)	525(118)	780(175)	1320(297)
Sensor switch	2 wire	RDVE(V): Non-contact (Please refer to page 5-10)									
	3 wire	RNFE(V): NPN, RPFE(V): PNP									
Weight (g)	80	110	150	240	400	540	1020	1880	3300	6200	

* Values for $\phi 16\sim\phi 25$ are with gripping length(L) = 20 mm, for $\phi 32\sim\phi 63$ with gripping length(L) = 30 mm, and for $\phi 80\sim\phi 125$ with gripping length(L) = 50 mm. Refer to "Effective Gripping Force" data for the gripping force at each gripping position.

Installation

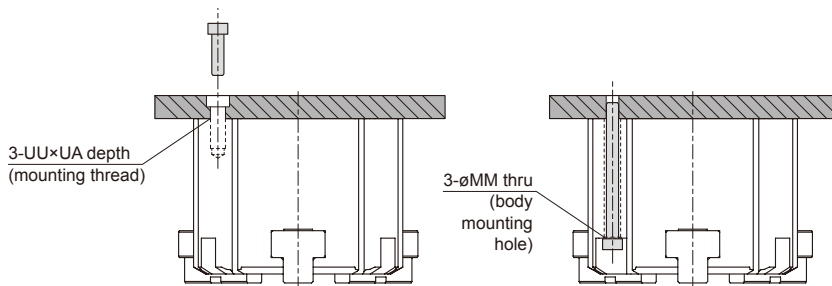

Model	MM	UU×UA	Bolt
MCHG2-16	3.4	M3×0.5×4.5	M3×0.5
MCHG2-20	3.4	M3×0.5×6	M3×0.5
MCHG2-25	4.5	M4×0.7×6	M4×0.7
MCHG2-32	4.5	M4×0.7×6	M4×0.7
MCHG2-40	5.5	M5×0.8×7.5	M5×0.8
MCHG2-50	5.5	M5×0.8×10	M5×0.8
MCHG2-63	6.6	M6×1.0×9	M6×1.0
MCHG2-80	6.6	M6×1.0×12	M6×1.0
MCHG2-100	9	M8×1.25×16	M8×1.25
MCHG2-125	11	M10×1.5×20	M10×1.5

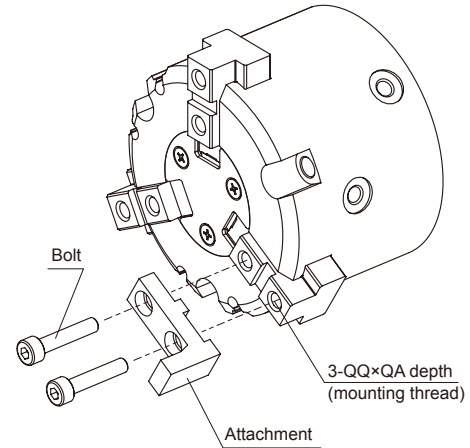
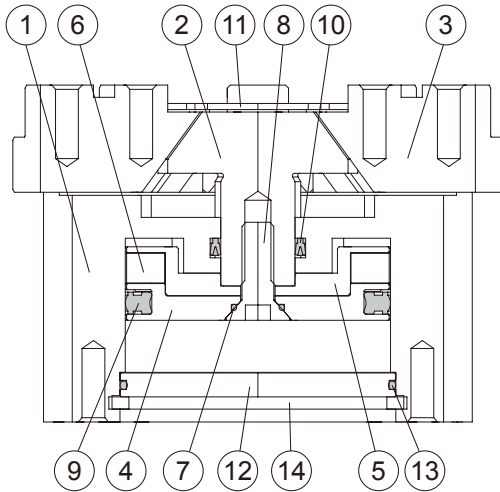

Material

No.	Part name	Material	Repair kits (inclusion)
1	Body	Aluminum alloy	
2	Lever	Carbon steel	
3	Slider	Carbon steel	
4	Piston	Aluminum alloy	
5	Piston-R	Aluminum alloy	
6	Magnet ring	Magnet material	
7	O-ring	NBR	●
8	Piston bolt	Carbon steel	
9	Piston packing	NBR	●
10	Rod packing	NBR	●
11	Table	Stainless steel	
12	End plate	Aluminum alloy	
13	O-ring	NBR	●
14	Snap ring	Carbon steel	

Mounting precautions

The tightening torque of slider mounting bolt, please refer to the table below.

Model	QQ×QA	Bolt	Max. tightening torque (N.m)
MCHG2-16	M3×0.5×5	M3×0.5	0.59
MCHG2-20	M3×0.5×6	M3×0.5	0.59
MCHG2-25	M3×0.5×6	M3×0.5	0.59
MCHG2-32	M4×0.7×8	M4×0.7	1.4
MCHG2-40	M4×0.7×8	M4×0.7	1.4
MCHG2-50	M5×0.8×8	M5×0.8	2.8
MCHG2-63	M5×0.8×8	M5×0.8	2.8
MCHG2-80	M6×1.0×12	M6×1.0	4.8
MCHG2-100	M8×1.25×16	M8×1.25	12
MCHG2-125	M10×1.5×20	M10×1.5	24

Order example of repair kits

Tube I.D.	Repair kits	Tube I.D.	Repair kits
ø16	PS-MCHG2-16	ø63	PS-MCHG2-63
ø20	PS-MCHG2-20	ø80	PS-MCHG2-80
ø25	PS-MCHG2-25	ø100	PS-MCHG2-100
ø32	PS-MCHG2-32	ø125	PS-MCHG2-125
ø40	PS-MCHG2-40		
ø50	PS-MCHG2-50		

Effective gripping force

* Finger selection please refer to page 3-2.

Indication of effective gripping force.

The effective gripping force shown in the graphs to the right is expressed as F , which is the thrust of one finger, when three fingers and attachments are in full contact with the workpiece as shown in the figure below.

1N=0.102 kgf
1MPa=10.2 kgf/cm²

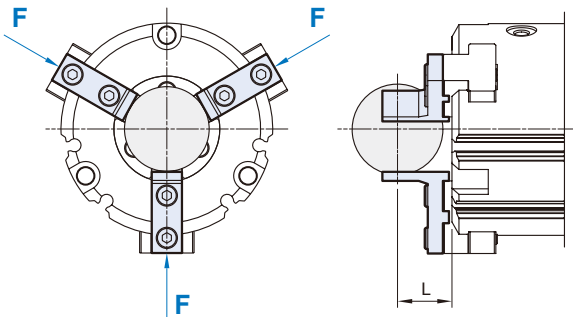

External grip

External gripping force

MCHG2-16

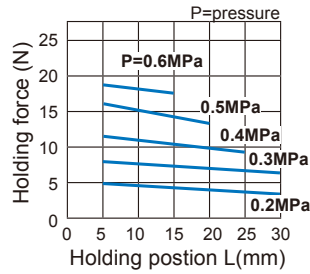

MCHG2-50

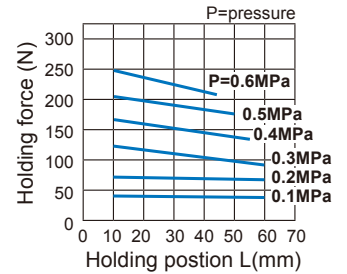

MCHG2-20

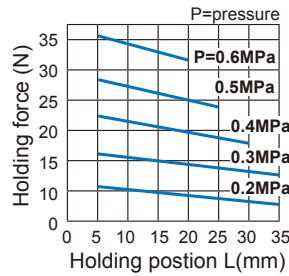

MCHG2-63

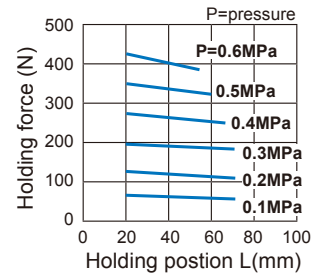

MCHG2-25

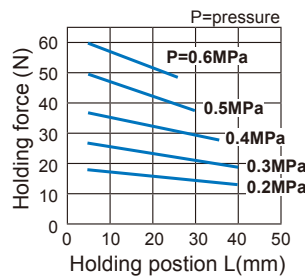

MCHG2-80

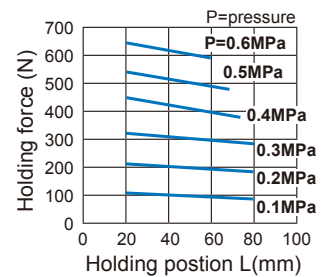

MCHG2-32

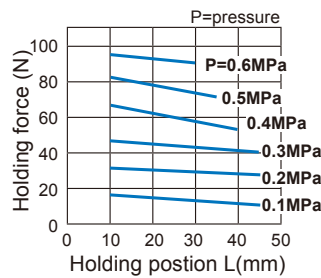

MCHG2-100

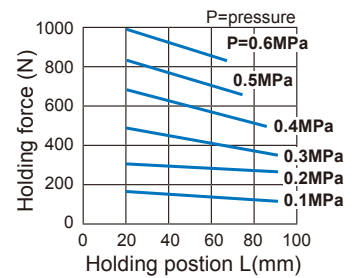

MCHG2-40

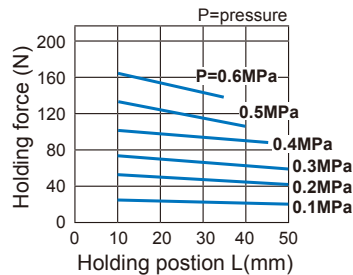

MCHG2-125

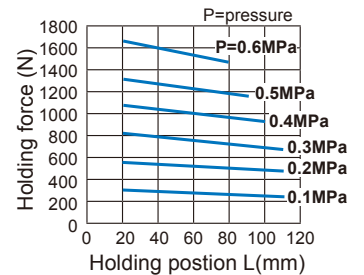

Effective gripping force

* Finger selection please refer to page 3-2.

Indication of effective gripping force.

The effective gripping force shown in the graphs to the right is expressed as F, which is the thrust of one finger, when three fingers and attachments are in full contact with the workpiece as shown in the figure below.

1N=0.102 kgf
1MPa=10.2 kgf/cm²

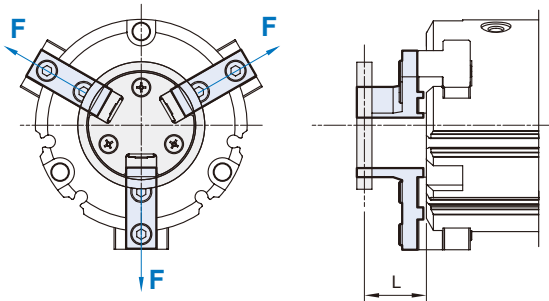

Internal grip

Internal gripping force

MCHG2-16

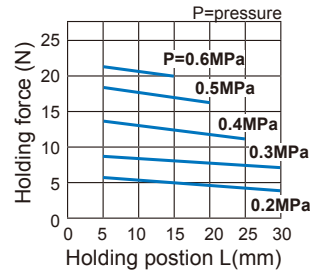

MCHG2-50

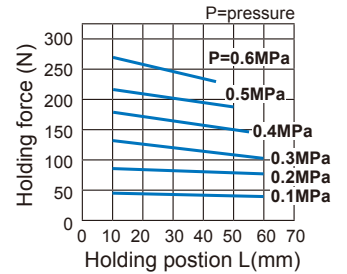

MCHG2-20

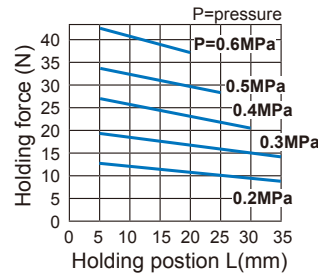

MCHG2-63

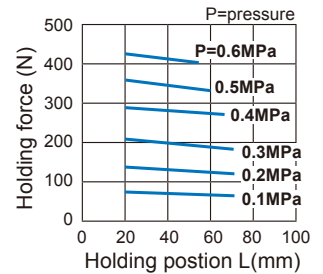

MCHG2-25

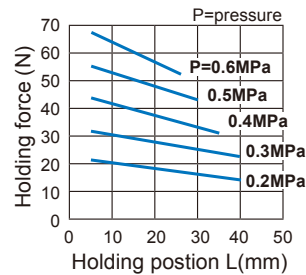

MCHG2-80

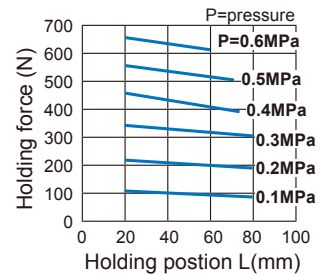

MCHG2-32

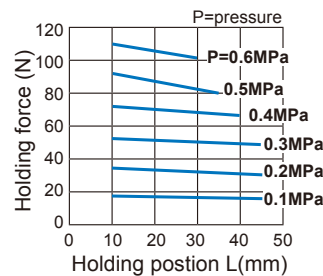

MCHG2-100

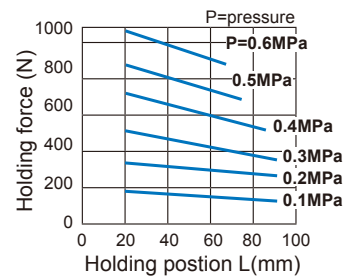

MCHG2-40

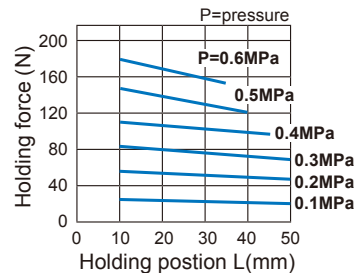

MCHG2-125

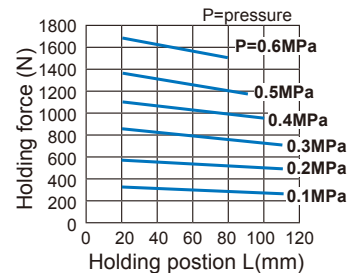

MCHG2 Dimensions $\phi 16 \sim \phi 25$



PARALLEL GRIPPER (3-Finger)

mindman

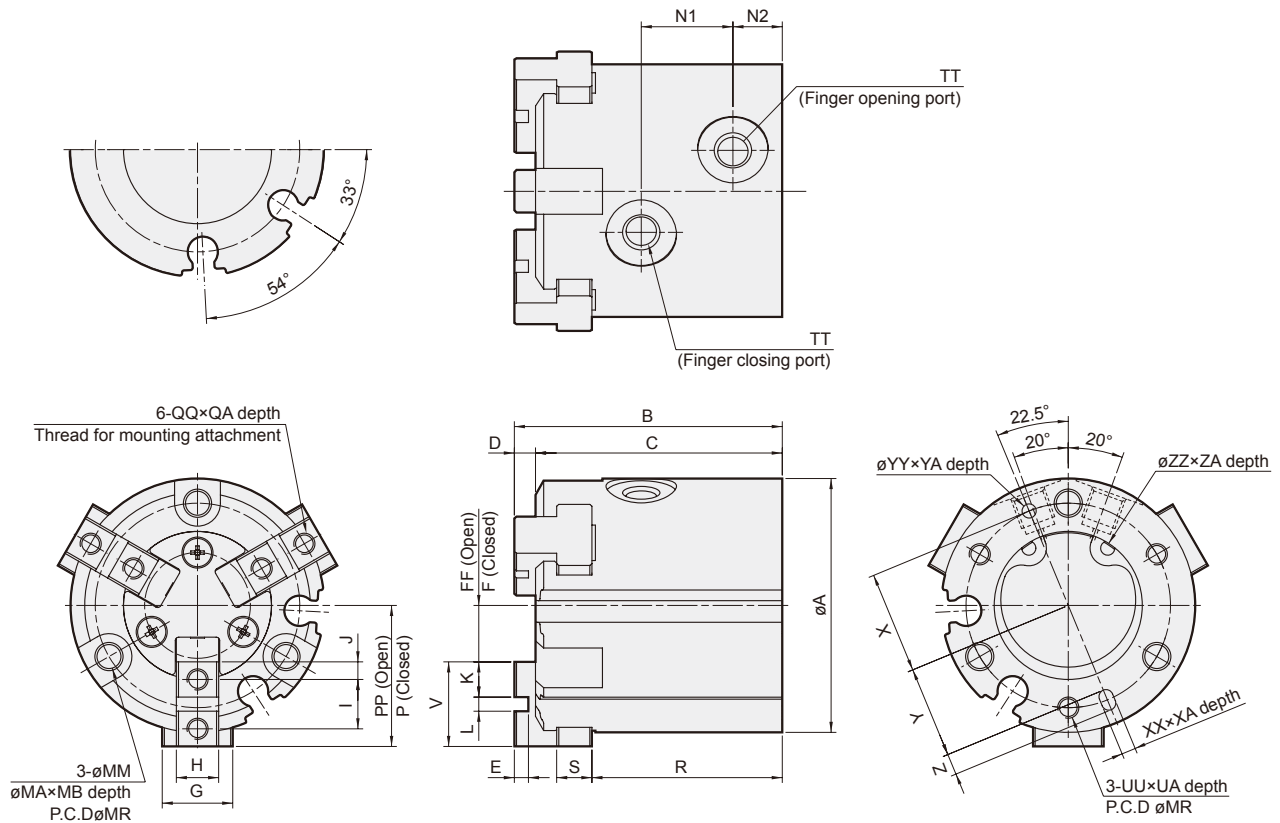

Code Tube I.D.	A	B	C	D	E	F	FF	G	H	I	J	K	L	MA	MB	MM	MR	N1	N2	P	PP	QA	QQ	R	S	TT
16	30	35	32	3	2	5	7	8	5h9 ⁺⁰ _{-0.030}	6	2	4	2H9 ^{+0.025} ₀	6.5	8	3.4	25	11	7	15	17	5	M3×0.5	25	4	M3×0.5
20	36	38	35	3	2	6	8	10	6h9 ⁺⁰ _{-0.030}	7	2.5	5	2H9 ^{+0.025} ₀	6.5	9.5	3.4	29	13	7	18	20	6	M3×0.5	27	5	M5×0.8
25	42	40	37	3	2	7	10	12	6h9 ⁺⁰ _{-0.030}	8	3	6	2H9 ^{+0.025} ₀	8	10	4.5	34	15	7	21	24	6	M3×0.5	28	5	M5×0.8

Code Tube I.D.	UA	UU	V	X	XA	XX	Y	YA	YY	Z	ZA	ZZ
16	4.5	M3×0.5	10	12.5	2	2H9 ^{+0.025} ₀	11	2	2H9 ^{+0.025} ₀	3	1.5	17H9 ^{+0.043} ₀
20	6	M3×0.5	12	14.5	2	2H9 ^{+0.025} ₀	13	2	2H9 ^{+0.025} ₀	3	1.5	21H9 ^{+0.052} ₀
25	6	M4×0.7	14	17	3	3H9 ^{+0.025} ₀	14.5	3	3H9 ^{+0.025} ₀	5	1.5	26H9 ^{+0.052} ₀

MCHG2 Dimensions $\phi 32 \sim \phi 125$



PARALLEL GRIPPER (3-Finger)

mindman

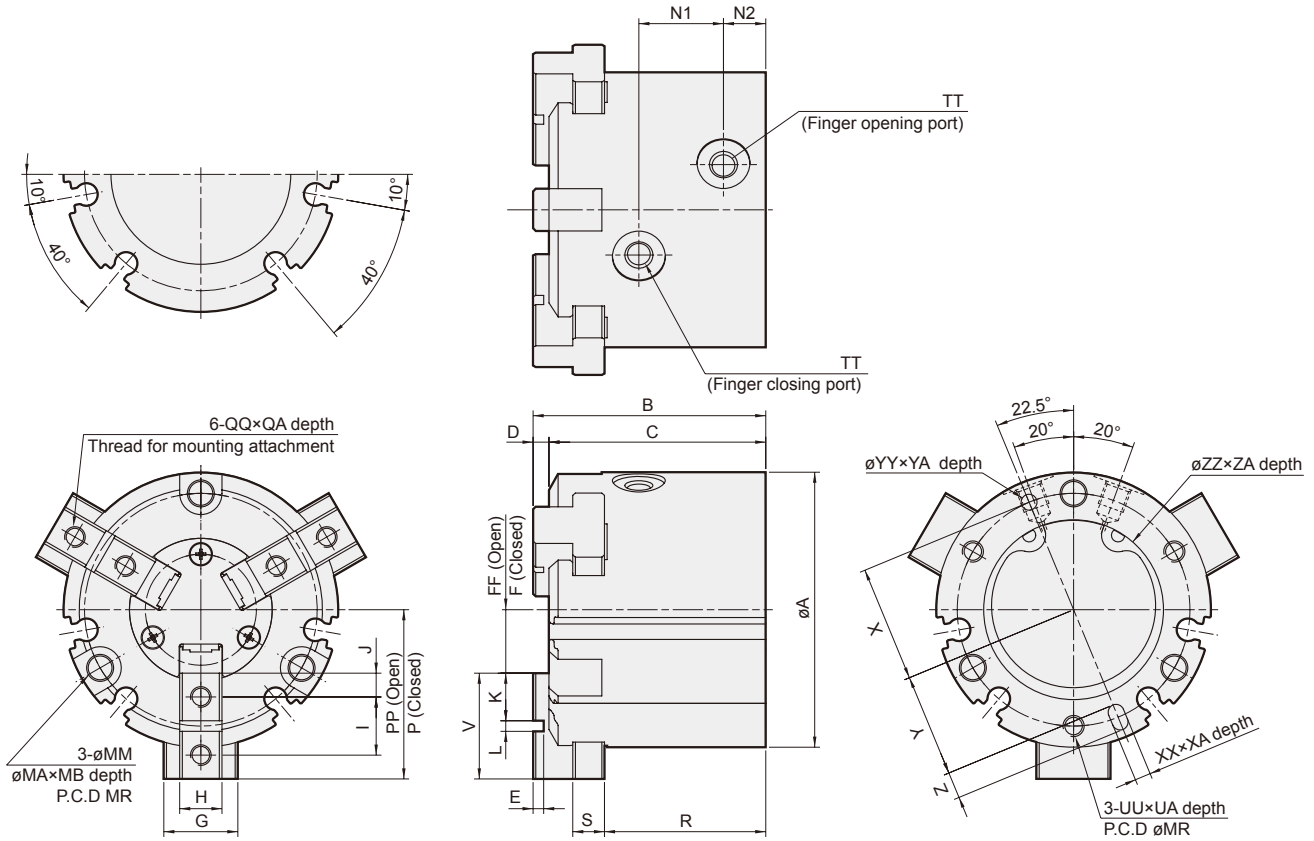

Code Tube I.D.	A	B	C	D	E	F	FF	G	H	I	J	K	L	MA	MB	MM	MR	N1	N2	P	PP	QA	QQ
32	52	44	41	3	2	8	12	14	8h9 ⁺⁰ _{-0.036}	11	4.5	9	2H9 ^{+0.025} ₋₀	8	9	4.5	44	16	8	28	32	8	M4×0.7
40	62	47	44	3	2	10	14	16	8h9 ⁺⁰ _{-0.036}	12	4.5	9	3H9 ^{+0.025} ₋₀	9.5	9	5.5	53	17	9	31	35	8	M4×0.7
50	70	55	52	3	2	11	17	18	10h9 ⁺⁰ _{-0.036}	14	5	10	4H9 ^{+0.030} ₋₀	9.5	12	5.5	62	20	9	35	41	10	M5×0.8
63	86	66	62	4	3	15	23	24	12h9 ⁺⁰ _{-0.043}	17	5.5	11	6H9 ^{+0.030} ₋₀	11	14	6.6	76	22	12	43	51	10	M5×0.8
80	106	82	77	5	4	21.5	31.5	28	14h9 ⁺⁰ _{-0.043}	20	6	12	8H9 ^{+0.036} ₋₀	11	19	6.6	95	27	13.5	53.5	63.5	12	M6×1.0
100	134	96	90	6	4	28	40	34	18h9 ⁺⁰ _{-0.043}	23	7.5	15	8H9 ^{+0.036} ₋₀	14	21	9	118	30.6	18	66	78	16	M8×1.25
125	166	122	114	8	6	30	46	40	22h9 ⁺⁰ _{-0.052}	31	10.5	21	10H9 ^{+0.036} ₋₀	17.5	34	11	148	38	23.5	82	98	20	M10×1.5

Code Tube I.D.	R	S	TT	UU	UA	V	X	XA	XX	Y	YY	YA	Z	ZA	ZZ
32	30.5	6	M5×0.8	M4×0.7	6	20	22	3	3H9 ^{+0.025} ₋₀	19.5	3H9 ^{+0.025} ₋₀	3	5	2	34H9 ^{+0.062} ₋₀
40	32	7	M5×0.8	M5×0.8	7.5	21	26.5	4	4H9 ^{+0.030} ₋₀	23.5	4H9 ^{+0.030} ₋₀	4	6	2	42H9 ^{+0.062} ₋₀
50	37.5	9	M5×0.8	M5×0.8	10	24	31	4	4H9 ^{+0.030} ₋₀	28	4H9 ^{+0.030} ₋₀	4	6	2	52H9 ^{+0.074} ₋₀
63	44	11	M5×0.8	M6×1.0	9	28	38	5	5H9 ^{+0.030} ₋₀	34.5	5H9 ^{+0.030} ₋₀	5	7	2.5	65H9 ^{+0.074} ₋₀
80	56	12	Rc1/8	M6×1.0	12	32	47.5	6	6H9 ^{+0.030} ₋₀	43.5	6H9 ^{+0.030} ₋₀	6	8	3	82H9 ^{+0.087} ₋₀
100	63	15	Rc1/4	M8×1.25	16	38	59	6	8H9 ^{+0.036} ₋₀	54	8H9 ^{+0.036} ₋₀	6	10	4	102H9 ^{+0.087} ₋₀
125	84	18	Rc3/8	M10×1.5	20	52	74	8	10H9 ^{+0.036} ₋₀	68	10H9 ^{+0.036} ₋₀	8	12	6	130H9 ^{+0.100} ₋₀